

FOOTING OPTION "A"***

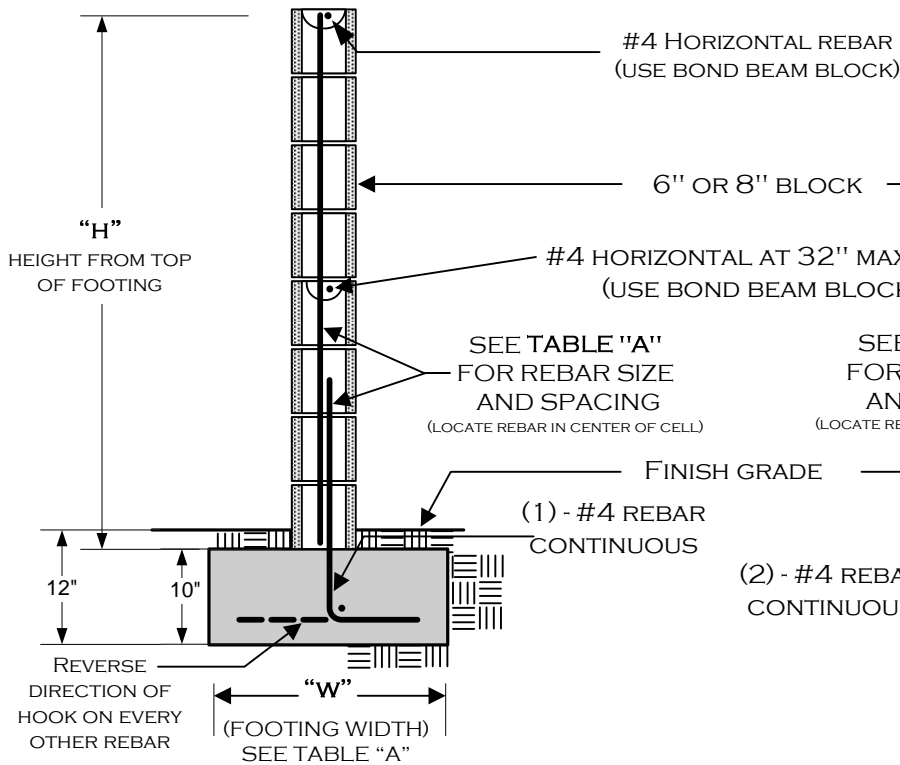

"H"	"W"	VERTICAL REINFORCEMENT
3'	17"	#4 @ 48" O.C.
4'	20"	#4 @ 48" O.C.
5'	23"	#4 @ 48" O.C.
6'	29"	#4 @ 24" O.C.

ALL FOOTINGS ADJACENT TO SLOPES TO BE AT LEAST 5' TO DAYLIGHT AS SHOWN BELOW.

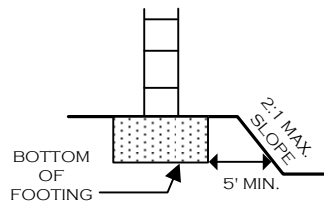

FOOTING OPTION "B"

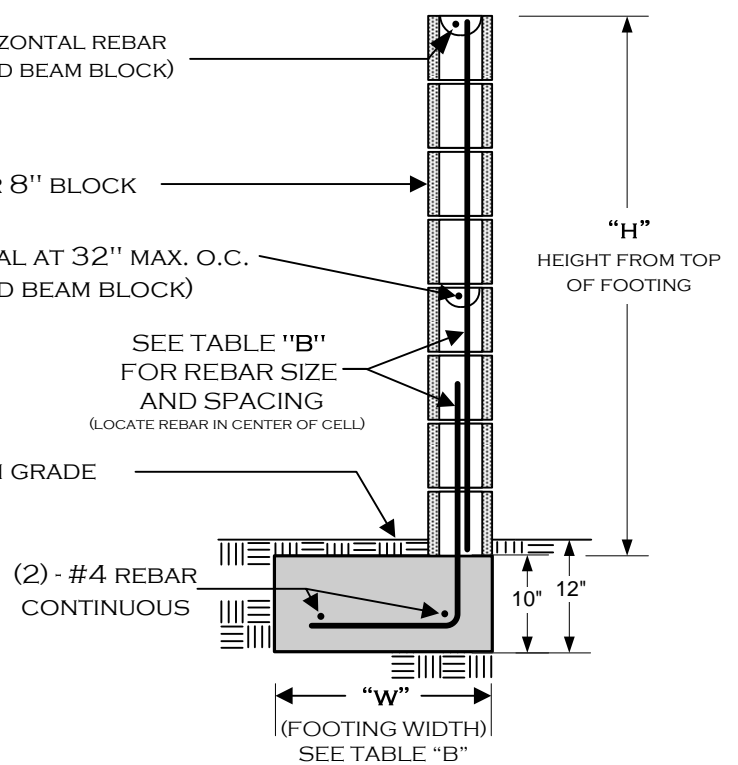

"H"	"W"	VERTICAL REINFORCEMENT
3'	19"	#4 @ 48" O.C.
4'	22"	#4 @ 48" O.C.
5'	29"	#4 @ 48" O.C.
6'	34"	#4 @ 24" O.C.

NOTES:

- 1) THIS DESIGN DOES **NOT** ALLOW GRADE DIFFERENTIALS OF MORE THAN 6" ON OPPOSING SIDES OF THE WALL. THIS IS **NOT** A RETAINING WALL.
- 2) FENCE HEIGHTS ARE REGULATED — CONSULT ZONING REGULATIONS BEFORE BEGINNING CONSTRUCTION.
- 3) NO WATER COURSE OR NATURAL DRAINAGE SHALL BE OBSTRUCTED.
- 4) GROUT **ONLY** THE CELLS CONTAINING REBAR. THIS WALL IS **NOT** DESIGNED FOR ALL CELLS TO BE GROUTED.
- 5) ALL REBAR TO BE ASTM SPEC. A615, GRADE 40 MINIMUM.
- 6) ALL REBAR LAP SPLICES TO BE 24" MINIMUM.
- 7) ALL MASONRY UNITS TO BE ASTM C-90 GRADE N.
- 8) REBAR TO BE CENTERED IN MASONRY CELLS.

SEE PAGE 2 FOR ADDITIONAL INFORMATION

DISCLAIMER:

ALTERNATE DESIGNS MAY BE POSSIBLE WHEN PROVIDED WITH AN ENGINEERED ANALYSIS. USE OF THIS STANDARD DESIGN IS AT THE USER'S RISK AND CARRIES NO IMPLIED OR INFERRED GUARANTEE AGAINST FAILURE OR DEFECTS.

CHECK WITH THE BUILDING DEPARTMENT TO VERIFY IF A BUILDING PERMIT IS REQUIRED.

WHEN A PERMIT IS REQUIRED, THE FOLLOWING INSPECTIONS ARE REQUIRED:

- 1) **FOOTING**; EXCAVATION TRENCH CLEAN WITH STEEL IN PLACE AND SUPPORTED 3" ABOVE AND AWAY FROM THE SURROUNDING EARTH/DIRT.
- 2) **REBAR/PRE-GROUT**; BOND BEAM REBAR AND VERTICAL REBAR IN PLACE - INSPECTION PRIOR TO PLACING GROUT.
- 3) **FINAL**; AFTER GROUT IS PLACED - PRIOR TO ANY DECORATIVE CAP PLACEMENT.

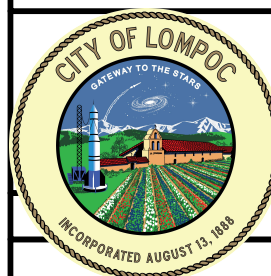

City of Lompoc
Building and Safety

Freestanding Block Wall

REBAR PLACEMENT ILLUSTRATION

FOOTING OPTION B

(TYPICAL)
ALL REBAR SPLICES
24" MIN. OVERLAP

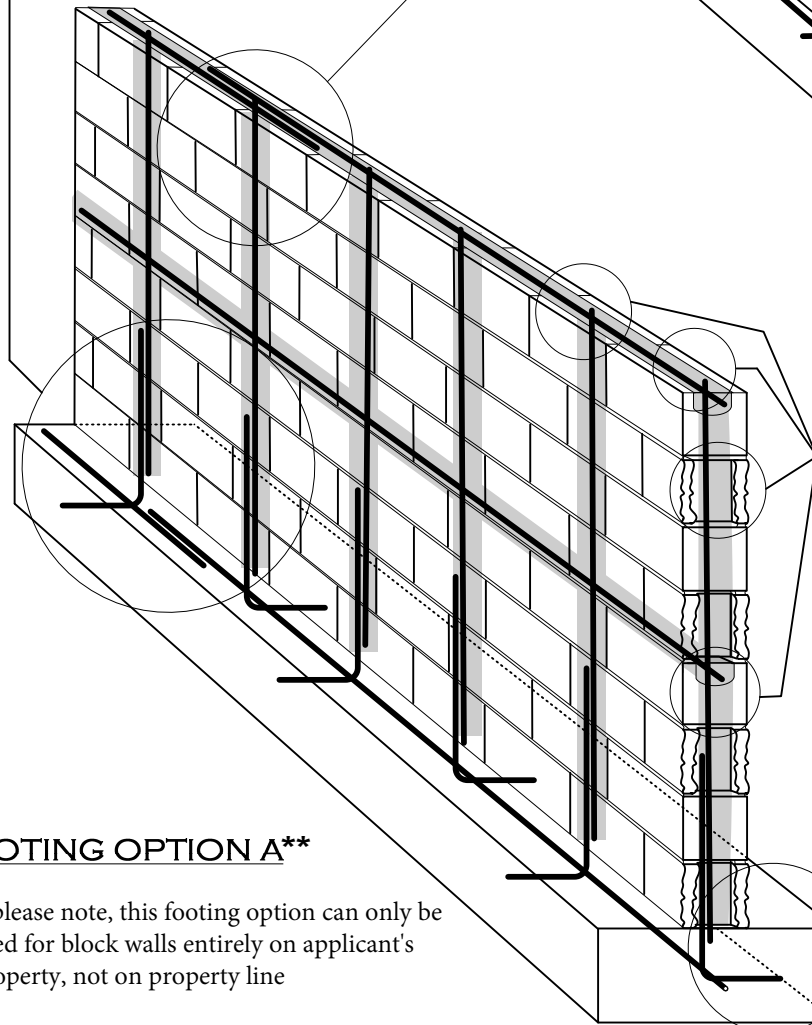
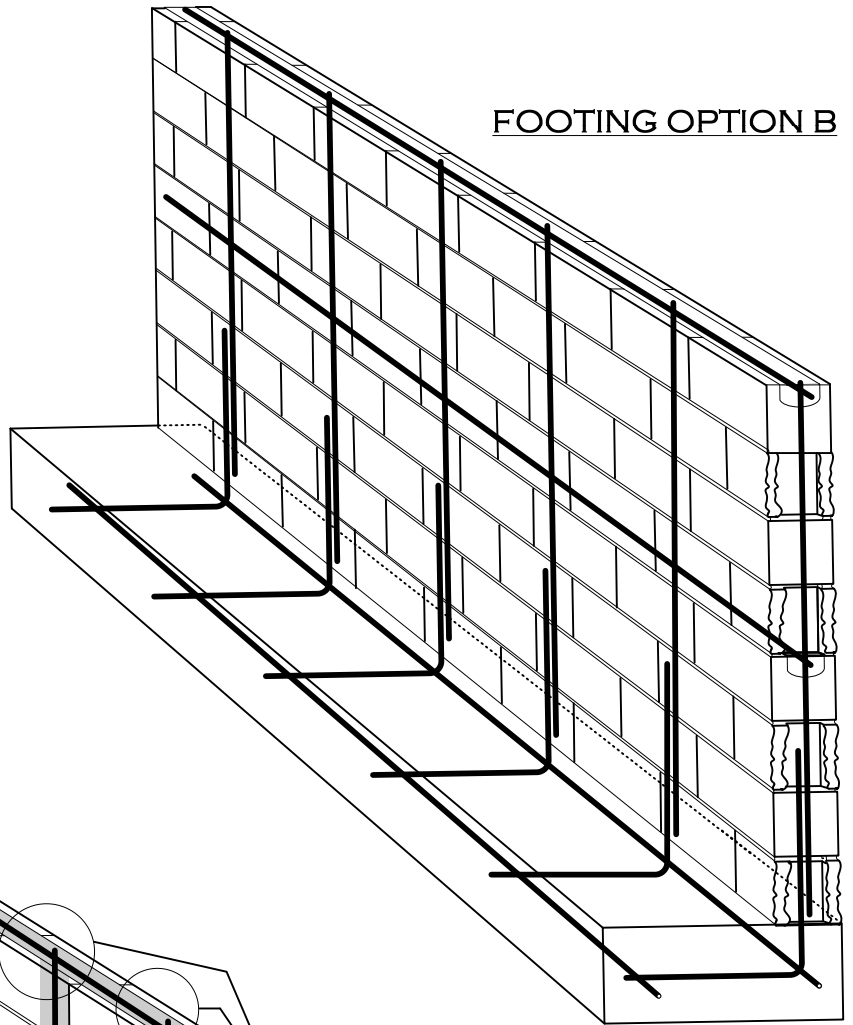

(TYPICAL)
ONLY CELLS AND BOND BEAM
COURSES WITH REBAR TO BE
GROUTED
(DO NOT SOLID GROUT ENTIRE WALL - USE
GROUT STOP MESH AS APPROPRIATE)

FOOTING OPTION A**

**please note, this footing option can only be used for block walls entirely on applicant's property, not on property line

(TYPICAL)
ALL REBAR SHALL HAVE A
MINIMUM OF 3" CONCRETE
COVER AT FOOTINGS

DESIGN PARAMETERS:

ACTIVE SOIL PRESSURE (PSF) = 30
 PASSIVE SOIL BEARING (PSF) = 150
 COEFFICIENT OF FRICTION = 0.25
 ALLOWABLE SOIL BEARING (PSF) = 1500
 WIND = 80 MPH, EXPOSURE C
 SEISMIC:
 NA=1.3, NV=1.6, Z=0.4, SOIL PROFILE=SD

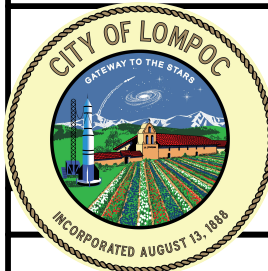

City of Lompoc
Building and Safety

Freestanding Block Wall